



Trans-  
Parancy™  
Glass  
Railings



## About EeStairs

EeStairs make feature stairs and balustrades of exceptional beauty, precision and structural integrity in Europe, North America and Asia. We work closely with leading architects, interior designers, engineers and high-profile commercial and private clients to produce stairs of outstanding formal, material, and technical quality.

EeStairs controls the entire stair-making and installation process. We collaborate in taking original designs through the final detailed and engineering stages. We fabricate according to the ISO9001 and ISO14001 quality systems in our BREEAM Outstanding factory. We then install the stairs and balustrades using our own experienced installation teams.

We are innovators. Our engineers and materials specialists continue to develop sophisticated, and often unique, detailing systems to ensure that our clients' original designs and specifications will always produce stairs of superb architectural quality – and also be a delight to use.

The culture of excellence at EeStairs is driven by a single intensely focused desire: to create Beauty Between Levels.



## What is TransParancy?

TransParancy™ structural glass balustrades give stairs a really streamlined look because they're pure glass, without visible fixings or supports, and can be used for straight or curved stairs, landings and balconies. The toughened glass is securely mounted and meets regulations and quality standards in Europe, the UK, and the US.

TransParancy™ balustrades sit in concealed steel or aluminium tracks and their pure lines recall the way glass was used so elegantly in classic modern architecture. TransParancy™ maximises light and visibility in spaces, and has been specified by leading architects such as Zaha Hadid Architects, OMA, UN Studio and Erick van Egeraat.



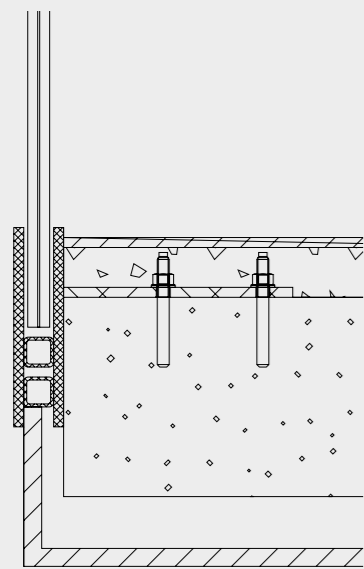

1-01 CB GO XL

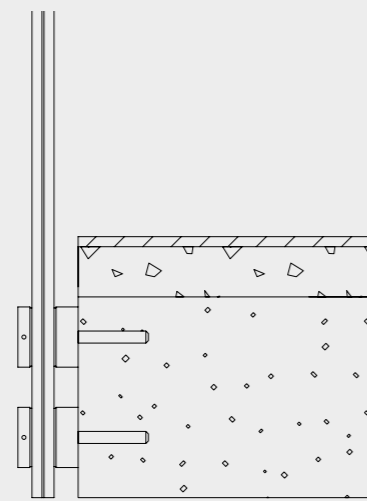

1-02 CB GO XL

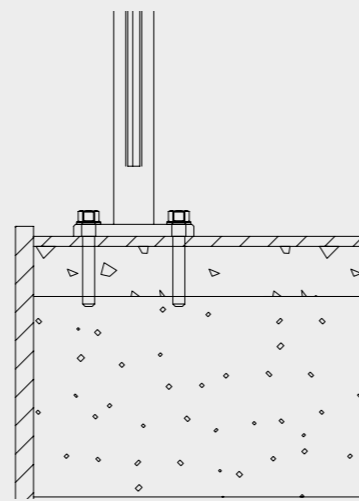

1-03



CB



GO

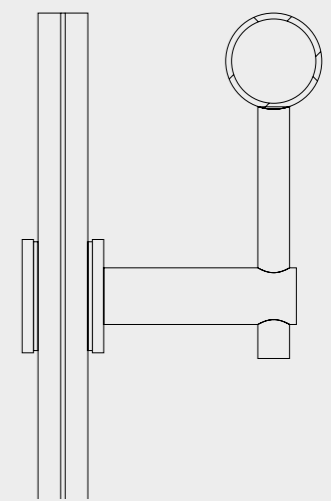

XL

## TransParancy Fixing

### 1-01:

The structural safety glass is mounted on a steel or aluminium track embedded below the floor.

### 1-02:

Stainless steel mechanical fixings are used to anchor 1-02 structural glass balustrade panels to the corresponding floor edge or staircase.

### 1-03:

The system is characterised by floor fixed balusters carrying glass infill and handrail. Since the handrail is carried by the balusters, the 1-03 doesn't have the CB, GO and XL options.

## TransParancy Handrails

### CB (Capped Balustrades)

The handrail on the balustrade makes it easy to grasp and the glass is protected at the top and base.

### GO (Glass Only)

Because this streamlined modern model is made solely of glass you hardly see the balustrade at all, which allows the environment to be shown to its fullest.

### XL (Extra Large)

This model is shown to best advantage in modern, minimalistic interiors. For those who don't just want any glass balustrade, the XL is a must.





# Port House, Antwerp



## Port House, Antwerp

Zaha Hadid Architects required a partner to produce a selection of TransParancy™ balustrades for the Port House in Antwerp.

Extending across the deck of the new interior to the staircase that provides access from the underground parking, the curved glass balustrades reach 3.5 metres in height at their tallest point.

EeStairs provided consultation in the early stages of the project, which involved complex contouring and careful measurement to ensure the TransParancy™ balustrades were installed correctly.









## TransParancy: The key benefits

- 1 — Clear. TransParancy™ guarantees a completely clear, clean-lined glass balustrade that provides an excellent contrast with other stair materials such as steel and wood.
- 2 — Safe. TransParancy™ balustrades meet or exceed safety standards for structural analysis, and impact and soft pendulum testing. They meet European, UK, and US regulations and quality standards, including NEN, British Standards, International Building Code, KOMO, and Bouwbesluit.
- 3 — Bespoke. TransParancy™ balustrades can be tailor-made, using glass panels from standard sizes to extra-large. The balustrades can be pure glass, glass with a thin metal top cap, or glass with banisters fitted securely and with minimal fixings to the inside face of the glass.
- 4 — Quality control. EeStairs controls the quality of TransParancy™ glass balustrades, from factory assembly to on site installation.

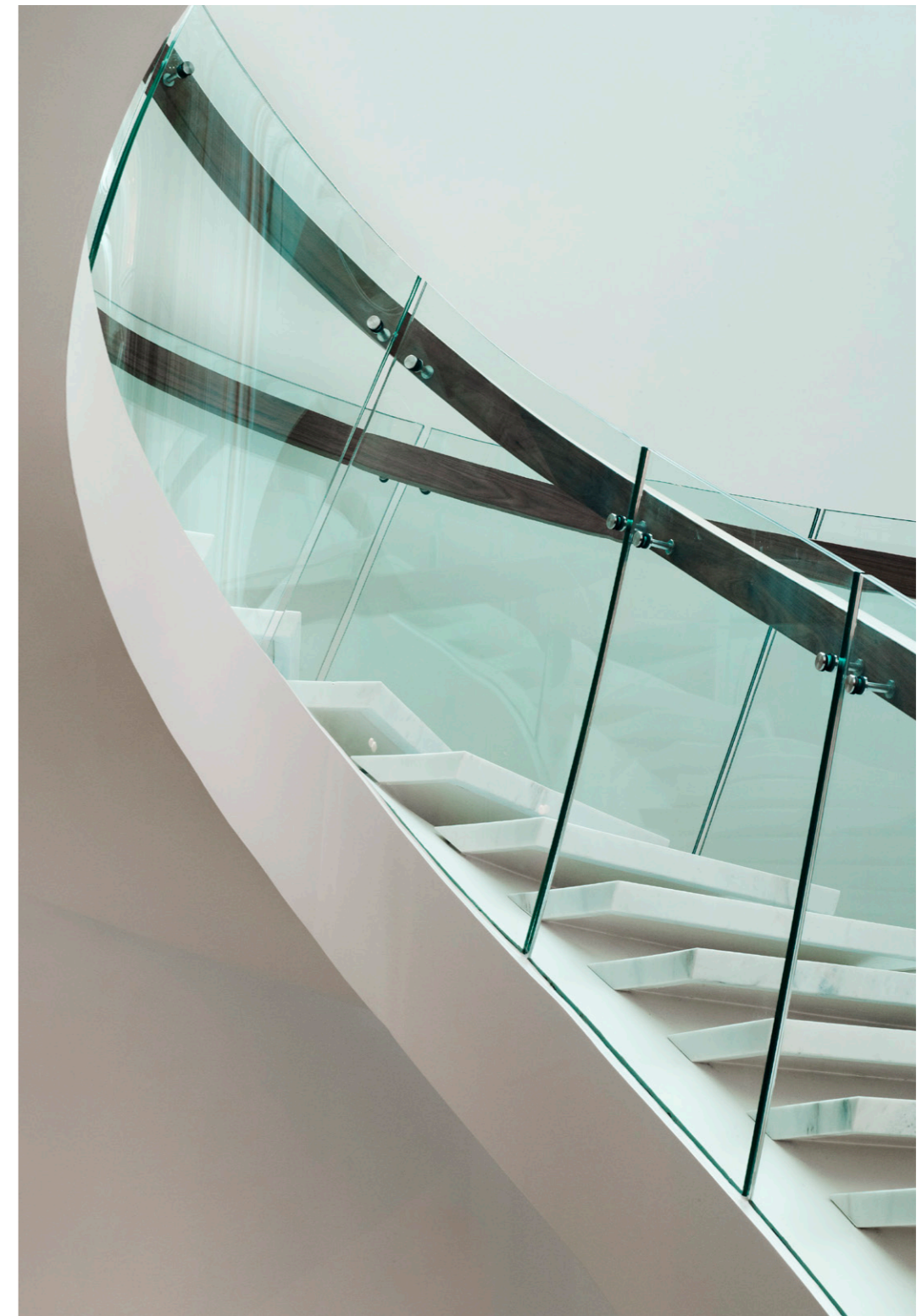





# Tridel, Toronto



## Tridel, Toronto

EeStairs made and installed the staircase in the reception area of the Tridel Design Centre in Toronto, operated by one of Canada's leading builder and developer of condominiums – and they believe that 'quality is never an accident, it's always the result of high intentions'.

The staircase's visual Wow Factor was obvious in its general form, and in the resolution of key details. The two flights, linked by a landing structurally connected to the reception's corner walls, are formed of thick marble-wrapped treads anchored to central steel spines.

The way the treads meet the laminated TransParancy™ balustrades was critically important. EeStairs ensured that the marble tread-ends met the glass perfectly so that the fixing bolts would 'lock' the treads securely into the glazing. Other important details were equally well-resolved: the precise line of the black mild steel handrails, and the junction of the two glass balustrades at the landing.









## Harmen talks TransParancy

Architecture writer Jay Merrick talks to Harmen van de Weerd, head of projects and engineering at EeStairs, about the TransParancy™ glass balustrades.

Jay Merrick – What is the key benefit of TransParancy™ balustrades?

Harmen van de Weerd – They accentuate architectural design quality. For example, working on Zaha Hadid Architects Havenhuis project in Antwerp, the dramatically angled TransParancy™ structural glass balustrade above the stairwell would have been ruined if there had been posts or other visible fittings.

JM – What glass is used?

HvdW – It's always toughened safety glass in two or more layers. In some specifications, laminated toughened glass is used.

JM – Is safety solely from the structural strength of the glass?

HvdW – No. The way the glass is seated directly into the stringer, or fixed to the sides of the risers, steps or posts is equally important.

JM – And what are the main options for designers?

HvdW – We can supply and fit glass-only TransParancy™ balustrades, or balustrades with metal or wood handrail caps. We can also make extra-large glass panels with handrails securely fitted to the inner face of the balustrade.

JM – Can TransParancy™ meet unusual design demands?

HvdW – Well, it can be made in curved glass panels, for example. And in one very interesting design, the TransParancy™ panels formed a continuous balustrade and stringer which sliced through the edges of the wooden steps.

JM – Which suggests that TransParancy™ is ideal for adventurous designers.

HvdW – Exactly. TransParancy™ is definitely not a one-trick-pony. It works in all design contexts!



It Works  
In All  
Design  
Contexts!





## Application

Because of their true TransParancy, TransParancy™ balustrades do not clutter views across sales spaces, or compromise the effects of lighting schemes designed to highlight products and create specific atmospheres.

In home interiors TransParancy™ balustrades are an excellent choice in interiors which are Modernist or avant garde in style, or where the designer or home-owner wants to display the other stair and room materials as clearly as possible. An excellent example is the sinuous TransParancy™ balustrade of the DNA stair in Sci Hundervood, Monaco.

And in commercial contexts, TransParancy™ balustrades have been used in car showrooms, shopping centres, visitor centres, and tech innovation parks.







## Specification 1-01

Model	1-01 CB	1-01 GO	1-01 XL
Handrail	∅ 42mm stainless steel	None	∅ 42mm stainless steel
Infill	Structural glazing (laminated, toughed and semi-tempered clear glass depending on the application)		
<b>Glass</b>			
Domestic:	900mm: CB 12	900mm: GO 8.8.2	900mm: XL 8.8.2
Public:	1.100mm: CB 12.12.12	1.100mm: GO 15.15.2	1.100mm: XL 15.15.2
Office:	1.100mm: CB 8.8.2	1.100mm: GO 10.10.2	1.100mm: XL 10.10.2
Floor Edge	Standard model includes 200mm deep fascia		
Height of stair balustrade	Between 900 and 1.000mm		
Height of landing/floor balustrade	900mm domestic, 1.100mm public		
Material	Steel, glass and stainless steel	Steel and glass	Steel, glass and stainless steel
Welding technique	Tig (virtually invisible)	None	Tig (virtually invisible)
Fixings	Base channel is fastened to edge of floor by M12 resin anchors. Glass bonded into channel and finished with bead of mastic		





## Specification 1-02

Model	1-02 CB	1-02 GO	1-02 XL
Handrail	∅ 42mm stainless steel	None	∅ 42mm stainless steel
Infill	Structural glazing (laminated, toughed and semi-tempered clear glass depending on the application)		
<b>Glass</b>			
Domestic:	900mm: CB 12	900mm: GO 8.8.2	900mm: XL 8.8.2
Public:	1.100mm: CB 12.12.12	1.100mm: GO 15.15.2	1.100mm: XL 15.15.2
Office:	1.100mm: CB 8.8.2	1.100mm: GO 10.10.2	1.100mm: XL 10.10.2
Floor Edge	Not included. The glass is attached to the existing floor edge with visible stainless steel fittings		
Height of stair balustrade	Between 900 and 1.000mm		
Height of landing/floor balustrade	900mm domestic, 1.100mm public		
Material	Glass and stainless steel (steel is optional)		
Welding technique	Tig (virtually invisible)	None	Tig (virtually invisible)
Fixings	Glass is fixed using M16 or M20 mechanical connections. Centre to centre distances are determined on site. To steel or wood: welded or bolted. To concrete: resin anchor.		

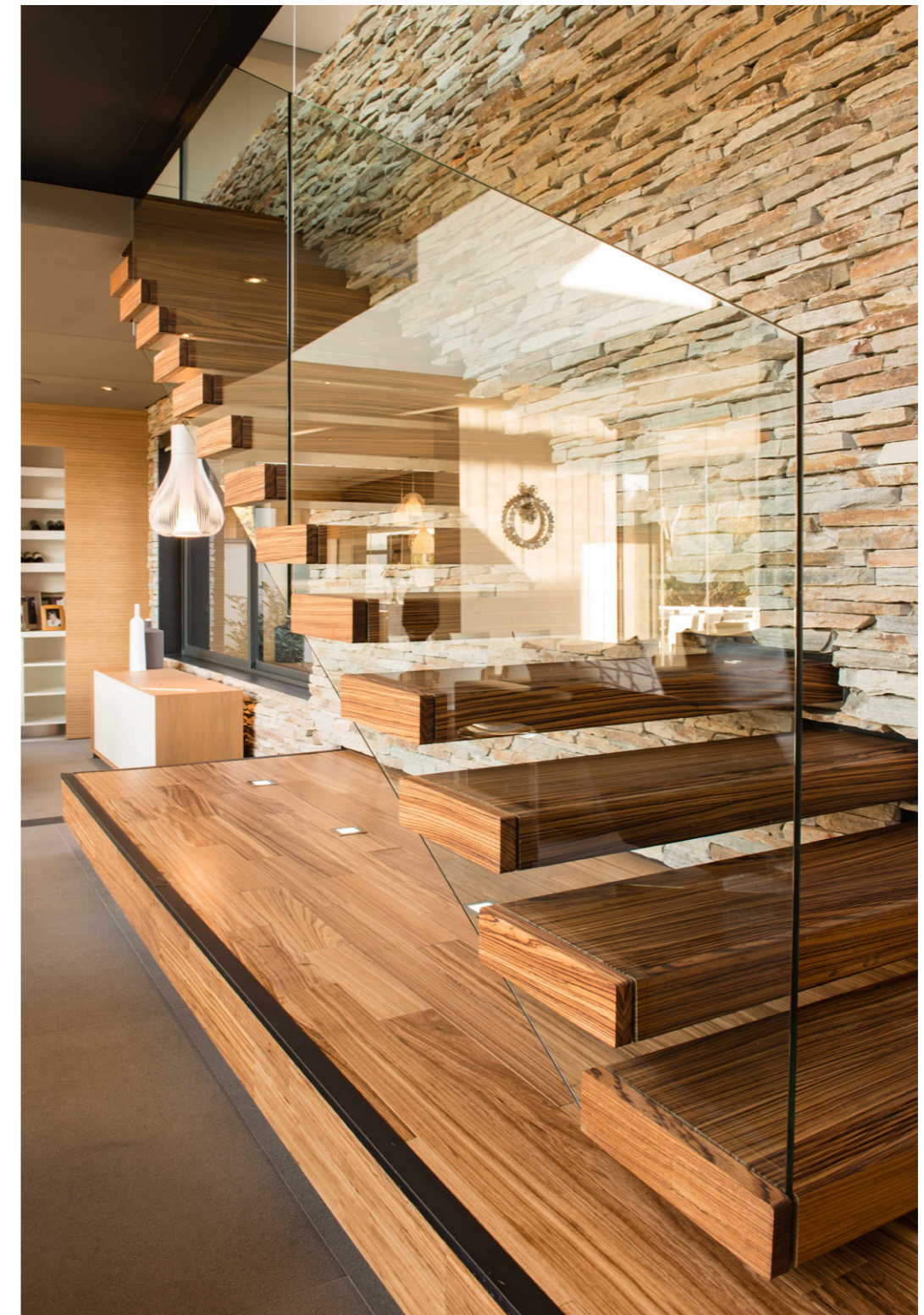



## Specification 1-03

∅ Handrail	Domestic: 42mm stainless steel tube Other: 48mm stainless steel tube
∅ Baluster	Domestic: 40mm stainless steel bar, slotted Other: 45mm stainless steel bar, slotted
∅ Handrail brackets	Domestic: 12mm stainless steel tube Other: 16mm stainless steel tube
Infill	Safety glass (laminated, toughed and semi-tempered clear glass. Specification to suit application)
Glass composition	Domestic: 55.2 Other: 66.2
Floor edge	Not applicable. Floor fixed balusters
Thickness foot plate	Domestic: 12mm Other: 15mm
Height of stair balustrade	Between 900 and 1.000mm
Height of landing/ floor balustrade	Between 1.000 and 1.100mm. 1.200mm is optional
Material	Stainless steel and glass. (Steel and timber optional.)
Welding technique	Tig (virtually invisible)

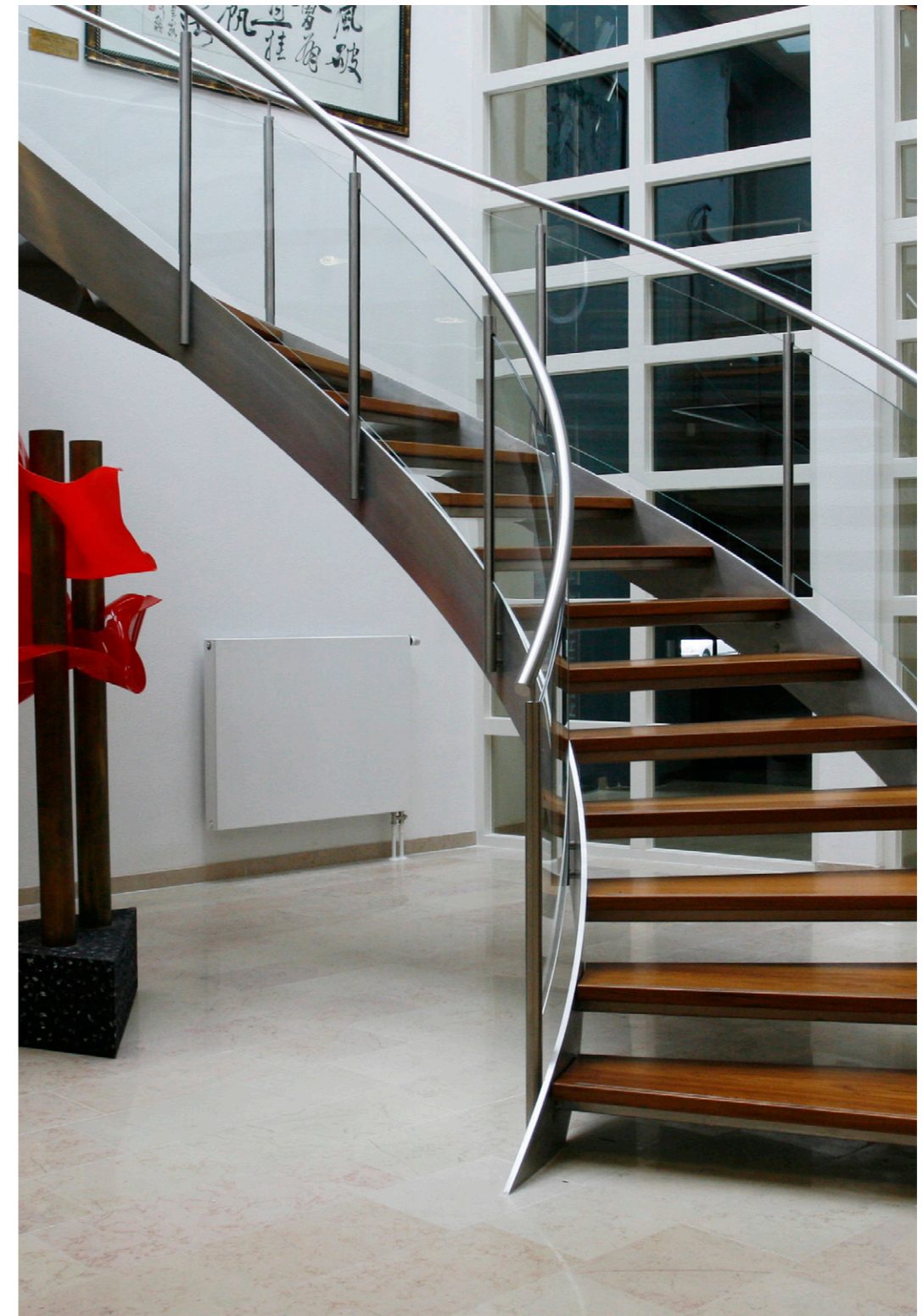



## Safety & Regulations

---

Balustrade protects users by providing guarding to voids and floor edges. Safety is a fundamental requirement and forms the basis of the TransParancy™ range. EeStairs' glass balustrade systems are put through rigorous testing procedures including structural analysis, impact testing and soft pendulum testing to ensure that they meet or exceed safety requirements.

The toughened glass sits securely in steel or aluminium tracks and has a structural rating which meets or exceeds quality and performance standards in Europe, the UK, and the US. Standards included are NEN standards and national and international regulations, such as Bouwbesluit (NL), British Standard (UK) and International Building Code (USA).

The balustrades are made in factory-controlled conditions and fitted by EeStairs installers.

## Innovations & Products

---

1m2™

Cells™

EeSoffit™

groovEe™

NextGen™

TransParancy™ 1-01

TransParancy™ 1-02

TransParancy™ 1-03

NEN

BSI

V EILIGHEIDS  
C HEKLUJST  
A ANNEMERS





Headquarters,  
The Netherlands  
& Export

EeStairs Nederland bv  
+31 342 405700  
nl@eestairs.com

---

USA & Canada

EeStairs America Inc.  
+1 (226) 381 0111  
info@eestairs.com

---

United Kingdom

EeStairs UK Ltd  
+44 5603 750 720  
uk@eestairs.com

---

Belgium

EeStairs BE  
+32 15 79 12 20  
be@eestairs.com

---

France  
Monaco  
Suisse

EeStairs FR  
+33 4 69 12 60 80  
fr@eestairs.com

---

Middle East

EeStairs ME  
+31 342 405700  
me@eestairs.com

---

China

EeStairs CHN  
+86 135 8653 7314  
chn@eestairs.com

---

Follow  
Online

@EeStairs  
[EeStairs.com](https://www.eestairs.com)